



**Murdoch**  
UNIVERSITY

**MURDOCH RESEARCH REPOSITORY**

**Authors Version**

**Safitri, N., Shahniah, F. and Masoum, M.A.S. (2014) Different techniques for simultaneously increasing the penetration level of rooftop PVs in residential LV networks and improving voltage profile. In: IEEE PES Asia-Pacific Power and Energy Engineering Conference (APPEEC) 2014, 7-10 December 2014, Hong Kong**

<http://researchrepository.murdoch.edu.au/32574/>

Copyright: © 2014 IEEE

It is posted here for your personal use. No further distribution is permitted.

Copyright © 2014 IEEE. Personal use of this material is permitted. Permission from IEEE must be obtained for all other uses, in any current or future media, including reprinting/republishing this material for advertising or promotional purposes, creating new collective works, for resale or redistribution to servers or lists, or reuse of any copyrighted component of this work in other works.

# Different Techniques for Simultaneously Increasing the Penetration Level of Rooftop PVs in Residential LV Networks and Improving Voltage Profile

Nelly Safitri, Farhad Shahnia and Mohammad A.S. Masoum  
Department of Electrical and Computer Engineering  
Curtin University, Perth, Australia  
nellysafitri@postgrad.curtin.edu.au

**Abstract**—Utilization of rooftop photovoltaic cells (PVs) in residential feeders without controlling their ratings and locations may deteriorate the overall grid performance including power flows, losses and voltage profiles. This paper investigates different methods for regulating the voltage profile and reducing the voltage unbalance at low voltage residential feeders. The algorithm considers reactive power exchange and active power curtailment of the single-phase rooftop PVs. In addition, it is assumed that the distribution transformers have on-load tap changers and can automatically control the voltage to prevent voltage rise in the feeder. The main objectives of the discussed methods are to regulate the voltage profiles and reduce the voltage unbalance. MATLAB-based simulation results demonstrate effectiveness of the discussed approaches.

**Keywords**—Rooftop PV, transformer tap changer, active power curtailment, reactive power exchange.

## I. INTRODUCTION

Nowadays rooftop photovoltaic cells are commonly used as the commercial distributed generation units (DGs) by householders in the residential feeders. They are connected to the network through power electronics-based converters. In the rest of the paper, for simplicity, a photovoltaic cell along with its converter is referred to as a PV system. The massive numbers of PVs in the network can change the direction of power flow and lead to voltage rise along the feeder [1]. In addition, most of the residential rooftop PV systems are single-phase units and their integrations into the three-phase networks might also cause unbalance issues due to their random locations and ratings [2]. References [3-4] further investigated the impact of high residential PVs penetration on voltage profiles due to the effect of feeder impedances, penetrations' level, the resistance of transformer short circuit and operation and protection of the feeders. These are some of the main issues and challenges that most electrical utilities are currently encountering and prevent the utilities from permitting the new householders to install rooftop PVs.

A variety of studies have investigated how to regulate voltage profile in the presence of high PVs penetration in the feeders. Reference [5] shows that rooftop PV inverters, when controlled in droop reactive power mode, can improve the voltage profile in a low voltage feeder. In this method, the PV inverters control their output voltages to a fixed value by

exchanging reactive power with the feeder. Reference [6] utilizes the droop-based active power curtailment to prevent overvoltage conditions in radial low voltage feeders. The most common mode of the voltage regulation in high voltage networks is the application of transformers with on-load tap changers (OLTC) [7]. However, transformers with OLTC are very expensive and only limited to high voltage networks. However, a traditional distribution transformer can be modified to act as a low voltage (LV) OLTC transformer by adopting semiconductor devices. In such a condition, a LV distribution with OLTC can regulate the voltage profile in the network [8].

This paper investigates the possibility of using distributed reactive power control and active power curtailment by single-phase rooftop PVs in three-phase unbalanced low voltage residential feeders. It is assumed that proper voltage monitoring and transmitting devices are available throughout the feeders to provide data transfer among the controllers of the rooftop PV inverters. The efficacy of the discussed methods in voltage regulation and voltage unbalance reduction are shown for a sample network using MATLAB simulation studies.

## II. PROBLEM FORMULATION AND PROPOSED SOLUTION

During noon periods, rooftop PVs usually generates their maximum power while the load demand in the network is at its minimum level. The high power generation by rooftop PVs can cause voltage rise in the network and force the voltage to exceed the maximum allowable limits. The voltage control option is considered in this paper in terms of its ability to maintain the voltage level. The injected reactive power and curtailed active power approaches can be applied for voltage amplitude control within the network when single-phase PVs are installed unequally at different phases and locations throughout the network and have different ratings. Reference [9] shows the possibility of utilizing the distributed reactive power support and active power curtailment by rooftop PVs in order to regulate the network voltage profile.

Utilization of the tap changing feature of transformers is an effective method for controlling the secondary voltage of transformer and hence regulating the voltage profile. The voltage control can take the actual load state of the transformer and the network into consideration. The result is that the voltage of a defined remote point of the network is

controlled, assuring that neither the consumers near to the bus, nor the consumers at the far ends of the network get voltages out of the required range. The voltage control function will be performed automatically.

### A. Network Under Consideration

Let us consider an 11 kV three-phase medium voltage feeder supplying a 415 V three-phase four-wire low voltage residential feeder, as shown in Fig. 1. This network topology is frequent in many countries including Australia [10]. The residential feeder is assumed to be unbalanced due to the distribution of loads and unequal distribution of single-phase rooftop PVs with different ratings.

### B. Network Modelling and Analysis

An unbalanced sweep forward-backward load flow method is developed in MATLAB and used for the analysis of the three-phase four-wire radial network under consideration. The load flow calculates bus voltages along the feeder. This method is discussed in detail in Appendix B.

### C. On-load Tap Changing LV Transformer

Voltage profile along the LV feeder should be kept within the recommended limits of 95% and 110% of the nominal voltage [10]. By utilizing a transformer with OLTC, the turns ratio of the transformer is adjustable. Fig. 2 shows the schematic diagram of a transformer with OLTC. Assuming a constant primary voltage, the transformer secondary voltage can be increased or decreased such that the voltage all along the feeder is kept within the acceptable limits.

The system operation is based on the assumption that two voltage sensors are installed in the network –one at the beginning of the feeder and one at the end of the feeder. Both of these voltage sensors are assumed to have data communication capability (using WiFi or ZigBee, etc.) to transfer the measured voltage to the master controller that is installed at the distribution transformer.

First, the feeder end voltage is monitored by the help of the installed voltage sensor and its data is transferred to the master controller. If the voltage at the end of the feeder is above the allowable limit, the master controller provide a proper command to the transformer tap changing system to activate a lower step. Hence, the voltage all along the feeder will reduce.

After this process, the feeder beginning voltage is monitored by the help of the installed voltage sensor and its data is transferred to the master controller. This voltage should be kept above the minimum allowable limit. Then, if the voltage at the end of the feeder is still above the maximum allowable limit, the process will be repeated to reasure the voltage all along the feeder is within the acceptable limit. Hence, by the help of a transformer with OLTC, the secondary voltage can be reduced upto a minimum of 80%.

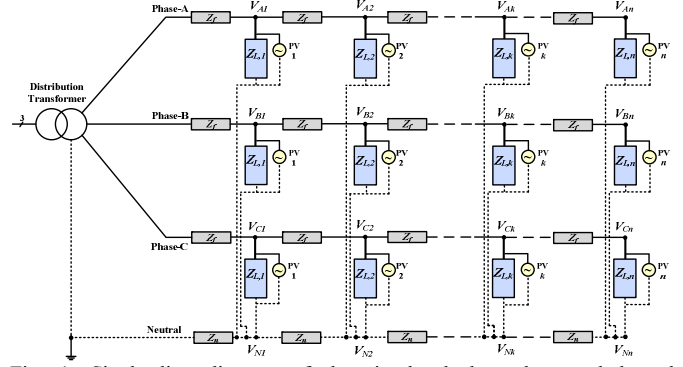

Fig. 1. Single line diagram of the simulated three-phase unbalanced residential LV network with single-phase rooftop PVs.

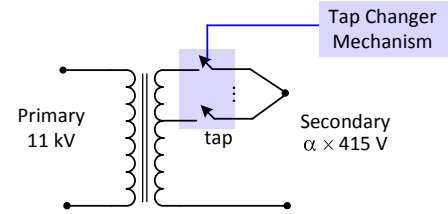

Fig. 2. Transformer configuration of changing turns' ratio by changing taps.

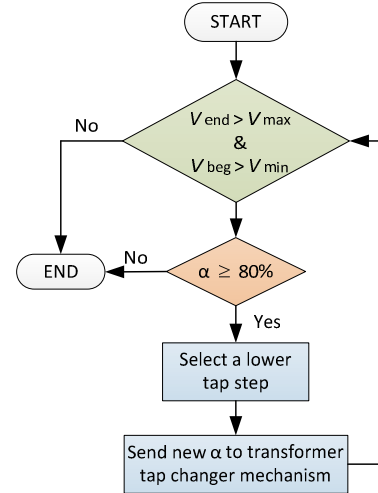

Fig. 3. Flow chart of tap changer control algorithm.

### D. Active and Reactive Power Control of PVs

Consider the LV feeder of Fig. 1 with 10 buses (nodes) where each node may have several single-phase PVs. The PV inverters currently operate in constant output power mode. Under such conditions, they only inject current with unity power factor and do not affect the voltage at their point of common coupling [8]. If the invetres are operated in voltage control mode, each PV can correct its own PCC voltage to a desired value by injecting or absorbing the required amount of reactive power ( $Q_{PV,ref}$ ). To minimiz the difference between the PCC voltage ( $V_{PCC}$ ) with its refernce value ( $V_{PCC,ref}$ ), each PV inverter needs to exchange reactive power with the feeder to keep the voltage of its output equal to the desired value based on the droop control strategy as

$$Q_{PV,ref} = m(V_{PCC,ref} - V_{PCC}) \quad (1)$$

where  $m$  is a coefficient and will be assigned by the reactive power-voltage ( $Q$ - $V$ ) droop controller. The  $Q$ - $V$  droop controller improves the dynamic oscillations between the reactive power and the voltage variation in the system. The calculated  $Q_{PV,ref}$  must be within the inverter capacity as

$$-\sqrt{S_{PV,max}^2 - P_{PV}^2} \leq Q_{PV,ref} \leq \sqrt{S_{PV,max}^2 - P_{PV}^2} \quad (2)$$

where  $S_{PV,max}$  is the maximum apparent power of the PV inverter. If the required  $Q_{PV,ref}$  is beyond its maximum injection or absorption capability, it will run on the maximum limits.

$V_{PCC,ref}$  will be defined as below:

- 1- If a PV is available on all three phases of bus  $i$ ,  $V_{PCC,ref}$  at this bus is equal to the average of the voltage magnitudes of the three phases, i.e.

$$V_{PCC,ref,k} = \frac{1}{3}(V_{a,k} + V_{b,k} + V_{c,k}) \quad (3)$$

- 2- If a PV is available only on two phases of node  $k$  (e.g. on phases b and c),  $V_{PCC,ref}$  at this bus is equal to the voltage magnitude of the third phase (e.g. phase a).
- 3- If a PV is available only on one phase of bus  $k$  (e.g. on phase a),  $V_{PCC,ref}$  at bus  $k$  is equal to the average of the voltage magnitudes of the other two phases, i.e.

$$V_{PCC,ref,k} = \frac{1}{2}(V_{b,k} + V_{c,k}) \quad (4)$$

- 4- If no PV is available on any of the phases of bus  $k$ , no  $V_{PCC,ref}$  will be defined for that bus and its voltage will not be directly controlled. However, the voltage of this bus will be affected by the change of the voltages at the other buses of the feeder.

Note that for each bus with rooftop PV,  $V_{PCC,ref}$  will be determined based on the data transmitted from the installed voltage sensors at each phase to the rooftop PV controller, by the help of the available WiFi or ZigBee communication network.

If the above method is not successful enough, the output active power of the PVs, dictated by the maximum power point tracking (MPPT) algorithm ( $P_{MPPT}$ ) can be controlled and reduced based on the error of the feeder voltage at a specific bus to prevent voltage rise or high voltage unbalance in the feeder, as

$$P_{PV} = P_{MPPT} - m'(V_{PCC,ref} - V_{PCC}) \quad (5)$$

where  $m'$  is a coefficient that needs to be defined to minimize the difference between the magnitudes of all three phase voltages.

### III. SIMULATION RESULTS

The network of Fig. 1 is modelled in MATLAB with the technical data given in Table 1 in the appendix. First, let us assume a case in which a single-phase PV system, with 5 kVA rating, is connected to all nodes of phase-A of the network. Let us assume the output active power of each PV is 5 kW. A few similar PVs are also located randomly in phase-B and C with locations as given in Table 2 in the appendix. As the PVs are utilizing all their capacities to generate active

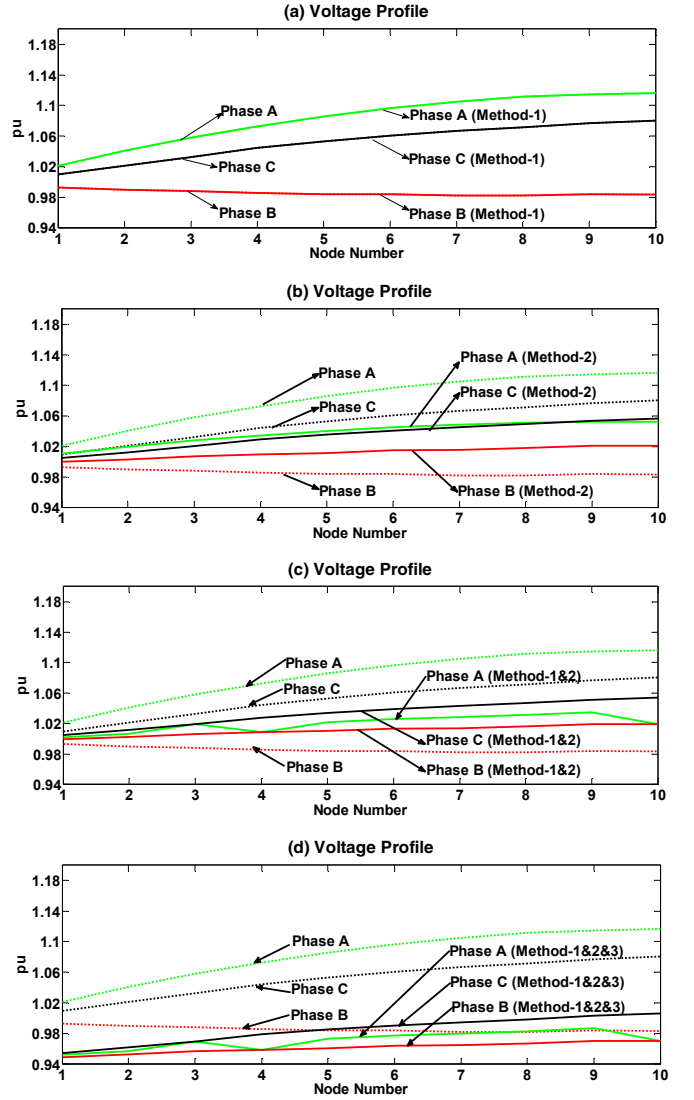

Fig. 4. Voltage profile of a three-phase residential network with high PV penetration before after applying improvement methods when the PVs do not have extra capacity to exchange reactive power.

power, their available capacity for reactive power exchange is zero. Hence after applying the reactive exchange strategy (method-1), there will be no effect on the voltage profile along the feeder. This is shown in Fig. 4(a).

To regulate the voltage profile and reduce the voltage unbalance, active power curtailment (method-2) can be applied to the PVs in the phase with highest PV generation (i.e. phase-A in this case). Fig. 4(b) shows the voltage profile before and after applying 50% active power curtailment to all the PVs located in phase-A. From this figure, it can be seen that the voltage unbalance is significantly reduced.

Under this condition, applying method-1 and 2 together does not lead to a significant difference. This is mainly due to the fact that the PVs located in phase-B and C do not have reactive power generation capacity and cannot contribute to voltage profile regulation. The result of this analysis is shown in Fig. 4(c).

To reduce the voltage rise problem due to high PV penetra-

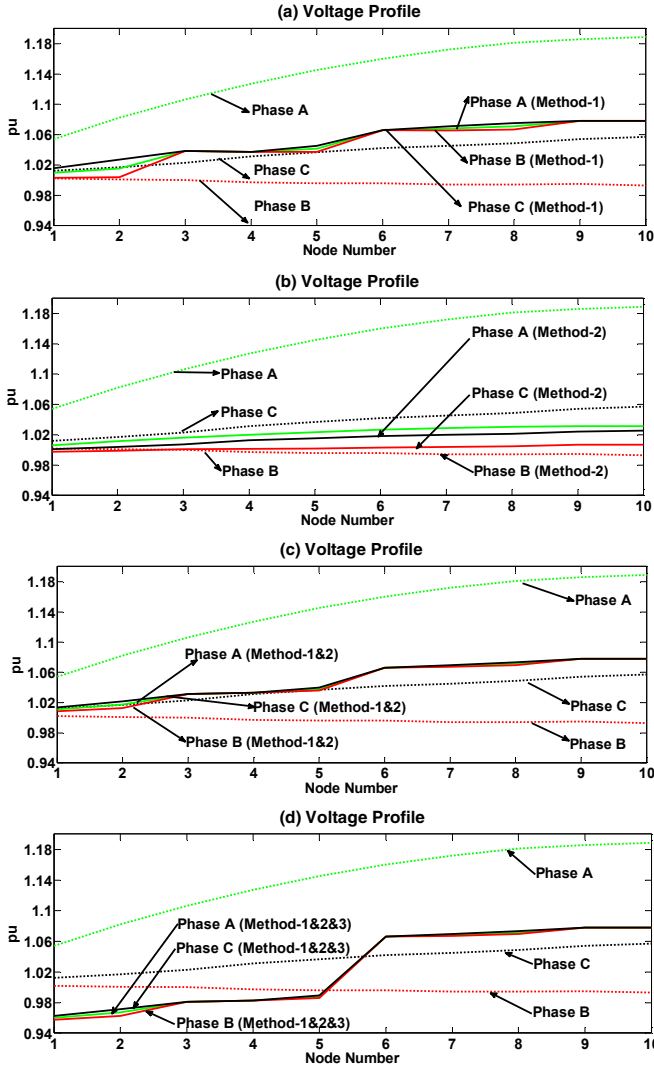

Fig. 5. Voltage profile of a three-phase residential network with high PV penetration before after applying improvement methods when the PVs have extra capacity to exchange reactive power.

ation in the network, the transformer secondary voltage can be slightly reduced by the help of its OLTC feature (method-3). In such a case, by applying the OLTC and then facilitating the reactive power exchange and active power curtailment, the voltage profile of the network can be significantly improved, as shown in Fig. 4(d).

Now, let us assume that all the PVs in the network are generating only 3 kW while their capacity is still 5 kVA. This extra capacity can be used for reactive power exchange. Under such conditions, after applying reactive power exchange strategy (method-1), the voltage profile can be improved significantly, as shown in Fig. 5(a).

By applying the active power curtailment (method-2), the voltage profile can also be improved, as shown in Fig. 5(b). However, this method is not as successful as method-1.

By applying method-1 and 2 together, the voltage profile results are very similar to those of method-1. This is shown in Fig. 5(c). As it can be seen from this figure, if the PVs have extra capacity to participate in reactive power exchange, the

voltage profile can be improved more, compared to the active power curtailment results.

By applying method-1, 2 and 3 together there is more control over reduction of the voltage rise along the feeder, as it is seen from Fig. 5(d). However, the results are not too different from the ones achieved by only applying method-1. This again shows that reactive power exchange (method-1) is the most effective way to control and regulate the voltage profile in the network for the conditions in which the PVs have extra capacity for reactive power exchange.

#### IV. CONCLUSION

The high penetration of single-phase rooftop PV systems that have different ratings and are located randomly within a three-phase residential feeder, can cause voltage rise and unbalance problems for the network. These problems can be effectively reduced if the PV systems are provided with reactive power exchange capability with the network. Alternatively, the output active power of the PVs needs to be curtailed, especially for the PVs located in a phase with high PV generation. In addition, utilization of a distribution transformer with on-load tap changing feature can significantly reduce the voltage rise problem in the network. These methods can also be applied together. Through the simulation studies carried out in PSCAD/EMTDC, it was shown that reactive power exchange is the most effective method if the PVs have available capacity for reactive power exchange. However, if extra capacity is not available in the PVs, then active power curtailment together with tap changing of the transformer are the suitable methods for voltage profile regulation. As a further step, the above discussed three methods can be combined together within an optimization concept to achieve better results.

#### APPENDIX

##### A. Network Data

The network data, utilized in the simulation studies, are provided in Table 1.

Table 1. Technical parameter of the studied LV distribution network.

|             |   |
|-------------|---|
| Transformer | 11/0.415 kV, 500 kVA, $\Delta/Y_{\text{grounded}}$ , $X_r=0.04$ pu          |
| MV Feeder   | Three-phase 11 kV radial $z = 1.08 + j \times 0.0302 \Omega/\text{km}$      |
| LV Feeder   | 415 V, 3-phase 4-wire, 400 m, $z = 0.452 + j \times 0.270 \Omega/\text{km}$ |

Table 2. Location and ratings of the PVs in the network under consideration.

| Node    | 1 | 2 | 3 | 4 | 5 | 6 | 7 | 8 | 9 | 10 |
|---------|---|---|---|---|---|---|---|---|---|----|
| Phase A | 5 | 5 | 5 | 5 | 5 | 5 | 5 | 5 | 5 | 5  |
| Phase B | - | - | 5 | - | - | 5 | - | - | 5 | -  |
| Phase C | - | - | - | 5 | - | 5 | - | - | 5 | 5  |

##### B. Unbalanced Load Flow for a Radial Feeder

An unbalanced sweep forward-backward load flow [11] is considered and integrated into the developed model. The load flow calculates the bus voltages along the feeder.

For this, first, modified Carson's equations [11] are utilized for calculation of self and mutual impedance of the conductors in the 50 Hz system as

$$Z_{ii} = r_i + 0.04934 + j0.062832 \left( \ln \frac{1}{GMR_i} + 7.10988 \right) \quad (6)$$

$$Z_{ij} = 0.04934 + j0.062832 \left( \ln \frac{1}{D_{ij}} + 7.10988 \right) \quad (7)$$

where  $i$  and  $j$  are the phase conductor (i.e. A, B, C or Neutral),  $Z_{ii}$  is the self-impedance of conductor  $i$  (in  $\Omega/\text{km}$ ),  $Z_{ij}$  is the mutual impedance between two conductors  $i$  and  $j$  (in  $\Omega/\text{km}$ ),  $r_i$  is the AC resistance of conductor  $i$  (in  $\Omega/\text{km}$ ),  $GMR_i$  is the Geometric Mean Radius of conductor  $i$  (in cm) and  $D_{ij}$  is the distance between conductor  $i$  and  $j$  (in cm). Hence, the non-transposed characteristics of the conductors, image conductors below ground and network configuration are considered in the studies. Fig. 6(a) shows the considered line configuration [10]. The three-phase four-wire line segment between two adjacent buses of  $k-1$  and  $k$  is also shown in Fig. 6(b). From (6) and (7), the equivalent impedance for this line section is expressed as

$$[Z_{abcn}] = \begin{bmatrix} Z_{aa} & Z_{ab} & Z_{ac} & Z_{an} \\ Z_{ba} & Z_{bb} & Z_{bc} & Z_{bn} \\ Z_{ca} & Z_{cb} & Z_{cc} & Z_{cn} \\ Z_{na} & Z_{nb} & Z_{nc} & Z_{nn} \end{bmatrix} \quad (8)$$

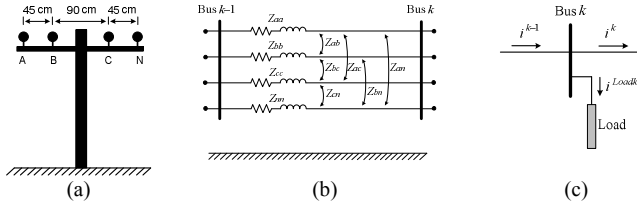

Fig 6. (a) Low voltage feeder configuration, (b) Impedance equivalent of a line segment between two buses, (c) PQ bus model.

Assuming the transformer with a delta/star-grounded connection, which is the common distribution transformed in Australia, and using Kron reduction, (8) can be rewritten as

$$[Z_{abc}] = \begin{bmatrix} Z_{aa-n} & Z_{ab-n} & Z_{ac-n} \\ Z_{ba-n} & Z_{bb-n} & Z_{bc-n} \\ Z_{ca-n} & Z_{cb-n} & Z_{cc-n} \end{bmatrix} \quad (9)$$

For simplicity, all calculations are carried out in per unit. Starting with a set of initial values (e.g. flat voltage set), the load currents are calculated as

$$[I_{abc}^{Load,k}] = \text{conj} \left( \frac{[P_{abc}^{Load,k}] + j[Q_{abc}^{Load,k}]}{[V_{abc}^k]} \right) \quad (10)$$

where  $[I_{abc}^{Load,k}]$  is a vector of three-phase load current connected to bus  $k$ ,  $[V_{abc}^k]$  is a vector of three-phase voltage of bus  $k$  and  $[P_{abc}^{Load,k}]$  and  $[Q_{abc}^{Load,k}]$  are respectively a vector of three-phase active and reactive power consumption of the residential load connected at bus  $k$ .

The sum of the all load currents will flow from the first bus (transformer secondary side) to the second bus. Therefore, as shown in Fig. 6(c), the current between two adjacent buses is

$$[I_{abc}^k] = [I_{abc}^{k-1}] - [I_{abc}^{Load,k}] \quad (11)$$

Hence, the voltage of bus  $k$  can be calculated based on the voltage of bus  $k-1$  in its upstream and the current passing between two buses as

$$[V_{abc}^k] = [V_{abc}^{k-1}] - [Z_{abc}][I_{abc}^k] \quad (12)$$

Once the voltage at bus  $k$  is calculated, the load current in that bus will be updated from (11) and then using (12) the current flowing from bus  $k$  to  $k+1$  in its downstream are updated.

Similar to the line segment, the equivalent impedance of the delta/star-grounded distribution transformer between its primary and secondary buses is expressed as

$$[Z_{abc}^k] = z_t \times I \quad (13)$$

where  $z_t$  is the phase impedance of the transformer and  $I$  is the identity matrix. Now, the secondary-side voltage of the transformer are calculated from its primary-side voltage as [11]

$$[Vt_{abc}^S] = [A][Vt_{abc}^P] - [Zt_{abc}][I_{abc}] \quad (14)$$

where  $[Vt_{abc}^P]$  and  $[Vt_{abc}^S]$  are respectively the primary and secondary-side phase voltages of the transformer and  $[I_{abc}]$  is a vector of three-phase current passing through the transformer and

$$[A] = \frac{1}{\sqrt{3}} \begin{bmatrix} 1 & 0 & -1 \\ -1 & 1 & 0 \\ 0 & -1 & 1 \end{bmatrix} \quad (15)$$

## REFERENCES

- [1] M. E. Baran, H. Hooshyar, S. Zhan, and A. Huang, "Accommodating High PV Penetration on Distribution Feeders," *IEEE Trans. on Smart Grid*, vol. 3, pp. 1039-1046, 2012.
- [2] F. Shahnia, A. Ghosh, G. Ledwich, and F. Zare, "Voltage Unbalance Reduction in Low Voltage Distribution Networks with Rooftop PVs," 20<sup>th</sup> Australasian Universities Power Engineering Conference (AUPEC), pp. 1-5, 2010.
- [3] R. Tonkoski, D. Turcotte, and T. H. M. El-Fouly, "Impact of High PV Penetration on Voltage Profiles in Residential Neighborhoods," *IEEE Trans. on Sustainable Energy*, vol. 3, pp. 518-527, 2012.
- [4] M. E. Baran, H. Hooshyar, S. Zhan, and A. Huang, "Accommodating High PV Penetration on Distribution Feeders," *IEEE Trans. on Smart Grid*, vol. 3, pp. 1039-1046, 2012.
- [5] R. Tonkoski, L.A.C. Lopes, and T.H.M. El-Fouly, "Droop-Based Active Power Curtailment for Overvoltage Prevention in Grid Connected PV Inverters," *IEEE Int. Symp. on Industrial Electronics (ISIE)*, pp. 2388-2393, 2010.
- [6] F. Shahnia, A. Ghosh, "Decentralized Voltage Support in a Low Voltage Feeder by Droop based Voltage Controlled PVs," 23<sup>rd</sup> Australasian Universities Power Engineering Conference (AUPEC), pp. 1-5, 2013.
- [7] Y. Liu, J. Bebic, B. Kroposki, et al., "Distribution System Voltage Performance Analysis for High-Penetration PV," *IEEE Energy 2030 Conference*, pp. 1-8, Nov. 2008.
- [8] Jawad Faiz and Behzad Siahkolah, *Electronic Tap Changer for Distribution Transformers*, Springer, 2011.
- [9] N. Safitri, F. Shahnia, and M. A. S. Masoum, "Coordination of Single-Phase Rooftop PVs to Regulate Voltage Profiles of Unbalanced Residential Feeders," 24<sup>th</sup> Australasian Universities Power Engineering Conference (AUPEC), Sept. 2014.
- [10] *Distribution Construction Standards Handbook*, Western Power, 2007.
- [11] W.H. Kersting, *Distribution System Modeling and Analysis*, CRC Press, 2012.